

## GPON OLT Optical Transceiver

### GPON-OLT-B+/C+/C++/C+++

#### NN-1490-2.5G-GPON

#### Features:

- Single fiber bi-directional data links asymmetric TX 2488Mbps/ RX1244Mbps application
- 1490nm continuous-mode DFB laser transmitter and 1310nm burst-mode APD-TIA receiver
- Small Form Factor Pluggable package with SC/UPC Connector
- 0 to 70°C operating temperature
- Single 3.3V power supply
- Digital diagnostic monitoring interface
- Digital burst RSSI function to monitor the input optical power level
- LVPECL compatible data input/output interface
- LVTTTL transmitter disable control
- LVTTTL transmitter laser fault alarm
- Fast LVTTTL receiver Signal Detect (SD) indication response
- Low EMI and excellent ESD protection
- Class I laser safety standard IEC-60825 compliant
- RoHS6 Compliance



#### Application :

Gigabit-capable Passive Optical Networks (GPON)

#### Standards:

- Complies with SFP Multi-Source Agreement (MSA) SFF-8074i
- Complies with ITU-T G.984.2 Amendment 1
- Complies with FCC 47 CFR Part 15, Class B
- Complies with FDA 21 CFR 1040.10 and 1040.11 except for deviations pursuant to Laser Notice No. 50, dated June 24, 2007
- Complies with SFF-8472
- Compatible with TR-NWT-000870 4.1 ESD sensitivity classification Class2.
- Compatible with Telcordia GR-468-CORE

## SFP information:

Part. No	Specifications				
	Package	Class	Temperature (°C)	Reach (km)	DDM
GPON-OLT-B+	SFP	GPON OLT Class B+	-5~70	20	Y
GPON-OLT-B+ IT	SFP	GPON OLT Class B+	-40~85	20	Y
GPON-OLT-C+	SFP	GPON OLT Class C+	-5~70	20	Y
GPON-OLT-C+ IT	SFP	GPON OLT Class C+	-40~85	20	Y
GPON-OLT-C++	SFP	GPON OLT Class C++	-5~70	20	Y
GPON-OLT-C+++	SFP	GPON OLT Class C+++ 7dBm	-5~70	20	Y

## Specification

Absolute Maximum Ratings				
Parameter	Symbol	Min	Max	Unit
Storage Ambient Temperature	T <sub>STG</sub>	-40	85	°C
Storage Humidity	H <sub>S</sub>	5	90	%
Operating Humidity	H <sub>O</sub>	5	85	%
Power Supply Voltage	V <sub>CC</sub>	0	+3.6	V
Receiver Damaged Threshold		+4		dBm

Recommended Operating Conditions						
Parameter	Symbol	Min	Typical	Max	Unit	Notes
Operating Case Temperature	T <sub>C</sub>	-5		70	°C	GPON-OLT-B+/C+/C++/C+++
		-40		85		GPON-OLT-B+/C+
Power Supply Voltage	V <sub>CC</sub>	3.135	3.3	3.465	V	
Supply Current	I <sub>CC</sub>			500	mA	
Power Consumption	P <sub>W</sub>			1.65	W	
Data Rate			TX 2.488 / RX 1.244		Gbps	

Electrical Characteristics						
Parameter	Symbol	Min	Typical	Max	Unit	Notes
Transmitter Differential Input Voltage		600		1600	mV	
Receiver Differential Output Voltage		400		1600	mV	LVPECL, DC Coupled
Transmit Fault Alarm Voltage	V <sub>OH</sub>	2.4		V <sub>CC</sub> +0.3	V	LVTTTL

Electrical Characteristics						
Parameter	Symbol	Min	Typical	Max	Unit	Notes
	V <sub>OL</sub>	0		0.4	V	LVTTTL
Transmit Disable Voltage	V <sub>IH</sub>	2		V <sub>CC</sub>	V	LVTTTL
	V <sub>IL</sub>	0		0.8	V	LVTTTL
Input Differential Impedance		90	100	110	Ω	
Transmit Disable Assert Time	T <sub>OFF</sub>			100	us	
Signal Detect Voltage	VOH	2.4		V <sub>CC</sub>	V	LVTTTL
	VOL	0		0.4	V	LVTTTL
Reset Signal	VOH	2.0		V <sub>CC</sub>	V	LVTTTL
	VOL	0		0.8	V	LVTTTL

Optical transmitter Characteristics						
Parameter	Symbol	Min	Typical	Max	Unit	Notes
Launched Power (avg.)	P <sub>OUT</sub>	+1.5		+5	dBm	GPON-OLT-B+
		+3		+7		GPON-OLT-C+
		+4.5		+8		GPON-OLT-C++
		+6	+7	+10		GPON-OLT-C+++
Operating Wavelength Range	λ <sub>C</sub>	1480		1500	nm	
Spectral Width (-20dB)	Δλ			1	nm	
Side Mode Suppression Ratio	SMSR	30				
Extinction Ratio	ER	8.2			dB	PRBS 2 <sup>23</sup> -1+72CID @2.488Gbit/s
Transmitter and Dispersion Penalty	TDP			1	dB	Transmit on 20km SMF
Optical Output Power after TX Disable	P <sub>DIS</sub>			-39	dBm	
Output Eye Diagram	Compliant with ITU-T G.984.2					
Transmitter Reflectance				-10	dB	
Optical Receiver Characteristics						
Parameter	Symbol	Min	Typical	Max	Unit	Notes
Wavelength Range	λ <sub>C</sub>	1260		1360	nm	
Receiver Sensitivity	SEN			-28	dBm	GPON-OLT-B+
				-30		GPON-OLT-C+
				-32		GPON-OLT-C++
				-32		GPON-OLT-C+++
Optical Power Input Overload	SAT	-8			dBm	GPON-OLT-B+
		-12				GPON-OLT-C+
		-15				GPON-OLT-C++

		-15				GPON-OLT-C+++
Dynamic Range		15			dB	Figure 1
Receiver Reflectance				-15	dB	

Note 1: PRBS  $2^{23}-1+72CID$  @1244Mbps, transmitter is operating, BER  $\leq 1 \times 10^{-10}$

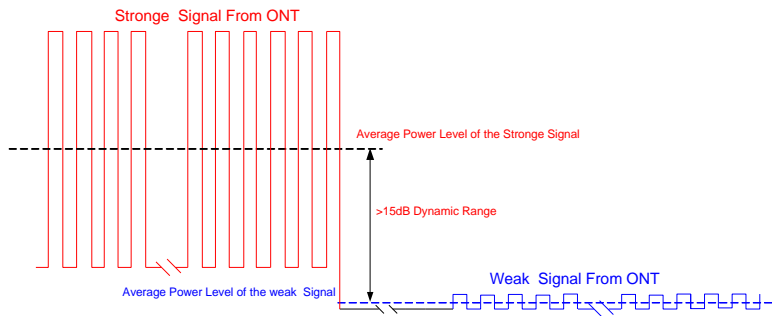

Figure 1 Burst Mode Receiver Dynamic Range in GPON System

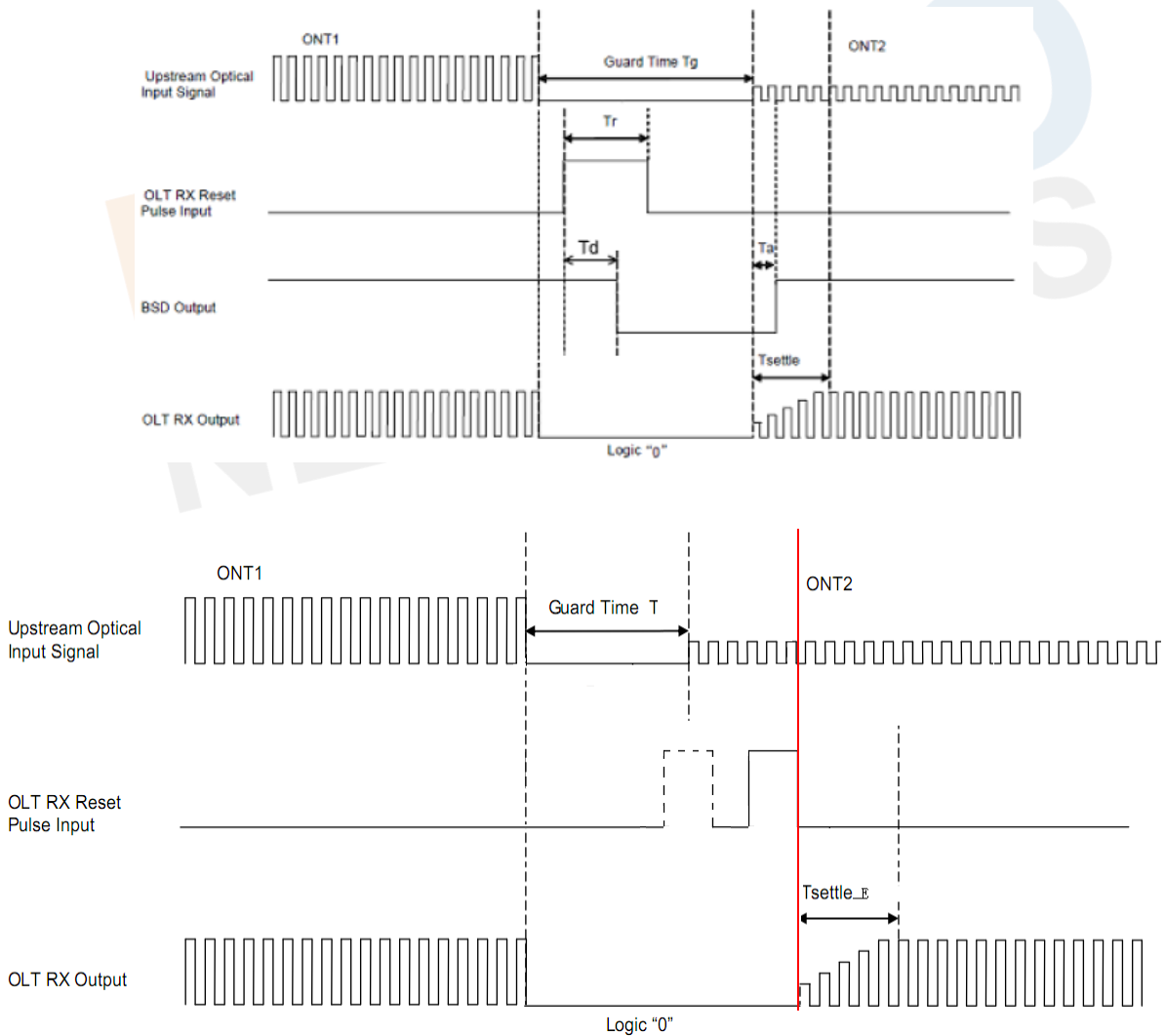

Figure 2 Burst Receiver Timing Sequence

Receiver Timing Characteristics						
Parameter	Symbol	Min.	Typ.	Max.	Unit	Notes
Guard Time	$T_G$	32			bit	
Reset Pulse Width <sup>(1)</sup>	$T_R$		16		bit	
Receiver Amplitude Recovery Time <sup>(2)</sup>	$T_{SETTLE}$			24	bit	
	$T_{SETTLE\_E}$			16	bit	
Signal Detect Assert Time	$T_A$			25	ns	
Signal Detect De-assert Time	$T_D$			10	ns	

(1) Reset Pulse support 2 modes in Figure2.

(2) SD signal pulls down immediately after Reset signal, and pulls up while detected RX burst signal till the next Reset signal.

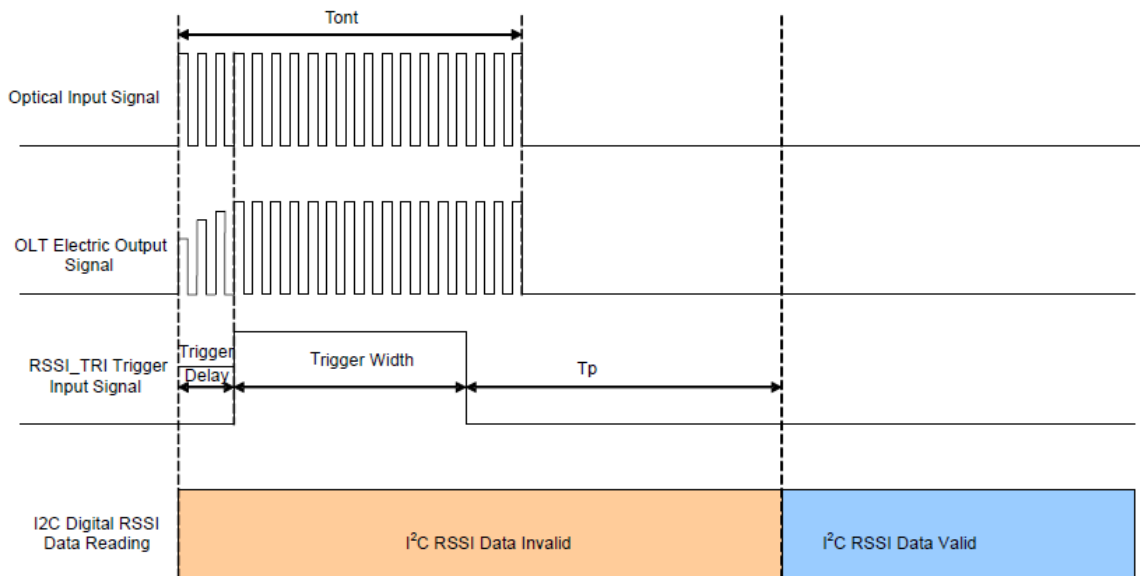

Figure 3 RSSI TIMING SEQUENCE

RSSI Characteristics						
Parameter	Symbol	Min.	Typ.	Max.	Unit	Notes
RSSI Trigger-Low		0		0.8	V	
RSSI Trigger-High		2.0		VCC	V	
RSSI Trigger Delay	$T_D$	0		3000	ns	
Optical Signal During Time	$T_{ONT}$	300			ns	
RSSI Trigger width	$T_W$	300		$T_{ONT} - T_D$	ns	
I2C Access Prohibited Time	$T_p$			500	$\mu$ s	

## Digital Diagnostic Monitoring Information

Parameter	Accuracy	Calibration	Note
Temperature	±3°C	External	
Voltage	±3%	External	
Bias Current	±10%	External	
TX Power	±3dB	External	
RX Power	±3dB	External	

**Note:** The digital diagnostic monitoring interface defines 256-byte memory map in EEPROM, which makes use of the 8 bit address 1010001X (A2h). Please refer to the SFF-8472 Rev 10.2 for the detail information.

## Pin definition:

Pin No	Symbol	Name/Description	Power Seq.	Note
1	V <sub>EE</sub> T	Transmitter Ground	1st	
2	TX Fault	Transmitter Fault Indication	3rd	High: abnormal; Low: normal
3	TX Disable	Transmitter Disable	3rd	High: transmitter disable; Low: transmitter enable. Internally 4.7k-10k ohm pull-up.
4	MOD-DEF2	Module Definition 2	3rd	The data line of two wire serial interface
5	MOD-DEF1	Module Definition 1	3rd	The clock line of two wire serial interface
6	MOD-DEF0	Module Definition 0	3rd	Connected to Ground in the transceiver
7	Reset	Receiver Reset	3rd	High: reset the receiver
8	SD	Signal Detect	3rd	High: signal detected; Low: loss of signal;
9	RSSI Trigger	RSSI Trigger for Transceiver A/D Conversion	3rd	High: enable RSSI A/D conversion
10	V <sub>EE</sub> R	Receiver Ground	1st	
11	V <sub>EE</sub> R	Receiver Ground	1st	
12	RD-	Inv. Receiver Data Out	3rd	LVPECL logic output, DC coupled
13	RD+	Receiver Data Out	3rd	LVPECL logic output, DC coupled
14	V <sub>EE</sub> R	Received Ground	1st	
15	V <sub>CC</sub> R	Receiver Power	2nd	
16	V <sub>CC</sub> T	Transmitter Power	2nd	
17	V <sub>EE</sub> T	Transmitter Ground	1st	
18	TD+	Transmit Data In	3rd	LVPECL logic input, AC coupled
19	TD-	Inv. Transmit Data In	3rd	LVPECL logic input, AC coupled
20	V <sub>EE</sub> T	Transmitter Ground	1st	

## Typical application Circuit

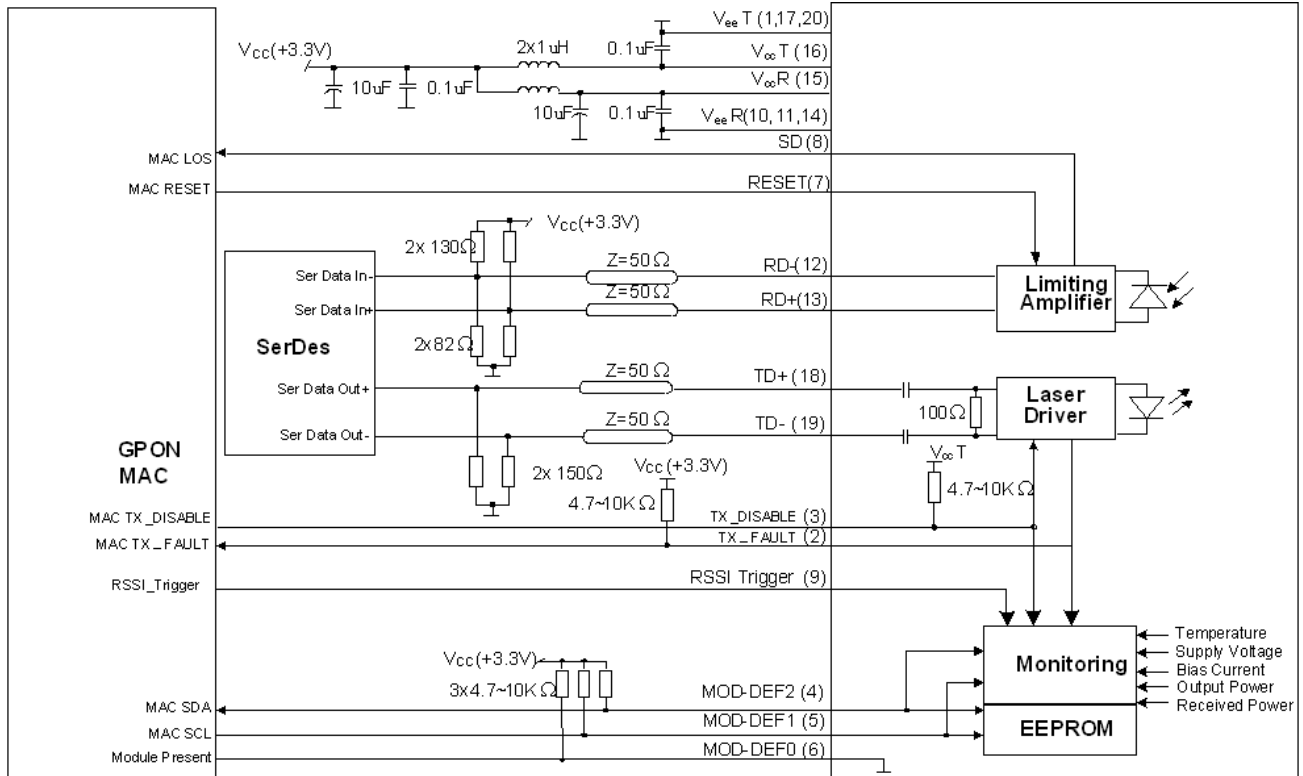

Figure 4 Typical Interface Circuit

## EEPROM Memory Map

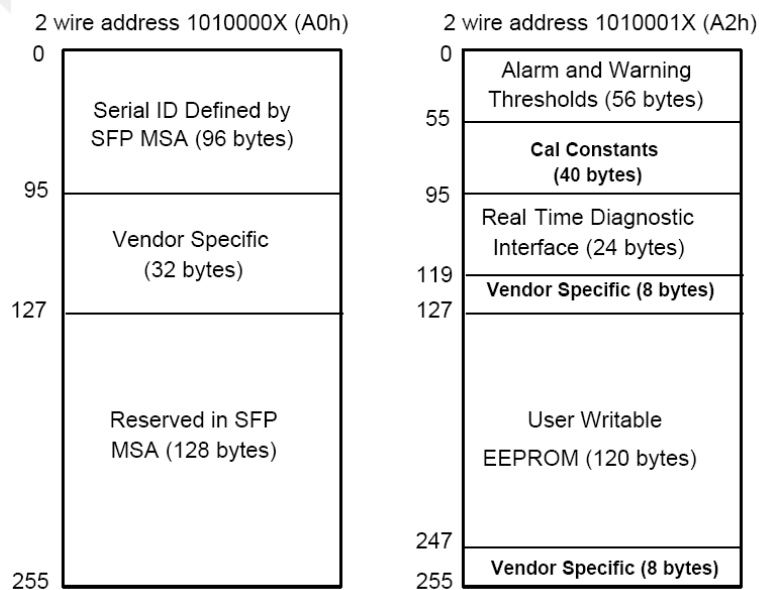

Figure 5 EEPROM Memory Map Specific Data Field Descriptions

## EEPROM Serial ID Memory Contents

The optical transceiver contains an EEPROM. It provides access to sophisticated identification information that describes the transceiver’s capabilities, standard interfaces, manufacturer, and other information. When the serial protocol is activated, the host generates the serial clock signal (SCL, Mod Def 1). The positive edge clocks data into those segments of the EEPROM that are not writing protected within the SFP transceiver. The negative edge clocks data from the SFP transceiver. The serial data signal (SDA, Mod Def 2) is bi-directional for serial data transfer. The host uses SDA in conjunction with SCL to mark the start and end of serial protocol activation. The memories are organized as a series of 8-bit data words that can be addressed individually or sequentially.

The Module provides diagnostic information about the present operating conditions. The transceiver generates this diagnostic data by digitization of internal analog signals. Calibration and alarm/warning threshold data is written during device manufacture. Received power monitoring, transmitted power monitoring, bias current monitoring, supply voltage monitoring and temperature monitoring all are implemented. The diagnostic data are raw A/D values and must be converted to real world units using calibration constants stored in EEPROM locations 56 – 95 at wire serial bus address A2h. The digital diagnostic memory map specific data fields define as following.

## EEPROM Serial ID Memory Contents (2-Wire Address A0h)

Address	Name of field	Hex	Description
<b>BASE ID Fields</b>			
00	Identifier	03	SFP transceiver
01	Ext. Identifier	04	Serial ID module supported for SFP
02	Connector	01	SC
03-05	Transceiver Codes	00 00 00	Not defined
06	Transceiver Codes	00	Not defined
07-10	Transceiver Codes	00 00 00	Not defined
11	Encoding	03	Encoding codes
12	BR, Nominal	19	
13	Rate Identifier	00	Not defined
14	Length(9um)-km	14	
15	Length(9um)-m	C8	
16	Length(50um)	00	Transceiver transmit distance
17	Length(62.5um)	00	
18	Length(cable)	00	Not support cable
19	Length(OM3)	00	Not support OM3
20-35	Vendor Name	xx xx .... xx	ASCII character
36	Reserved	00	Not defined
37-39	Vendor OUI	00 00 00	Not defined
40-55	Vendor P/N	47 54 53 2D 53 47 54 32 31 2D 32 30 44 43(49) 2D 42(43/44/45)	ASCII character
56-59	Vendor P/N Rev.	30 20 20 20	“A0”(ASCII character)
60-61	Laser Wavelength	05 D2	1490nm



62	Reserved	00	Not defined
63	CC_BASE	xx	Check sum of bytes 0-62
<b>Extended ID Fields</b>			
64-65	Options	00 1C	TX_Disable、TX_Fault and RX_SD are implemented
66	BR, max	00	Upper bit rate margin,20%
67	BR, min	00	Lower bit rate margin,20%
68-83	Vendor SN	xx.....xx	Vendor Serial Number in ASCII character
84-91	Date Code	Data Code	Vendor Date Code in ASCII character
92	Diagnostic Monitoring Type	68	Digital Diagnostic monitoring implemented "Internal calibrated " is implemented, RX measurement type is "Average Power"
93	Enhanced options	E0	Optional Alarm/warning flags, soft Tx_Disable control and monitoring, soft Tx_Fault monitoring are implemented
94	SFF-8472 compliant	03	SFF-8472 compliant with revision 10.2
95	CC-EXT	xx	Check sum of bytes 64-94
<b>Vendor Specific ID Field</b>			
96-127	Vendor Specific	00	Vendor specific EEPROM
128-255	Reserved	00	Reserved for future use

## Package Outline

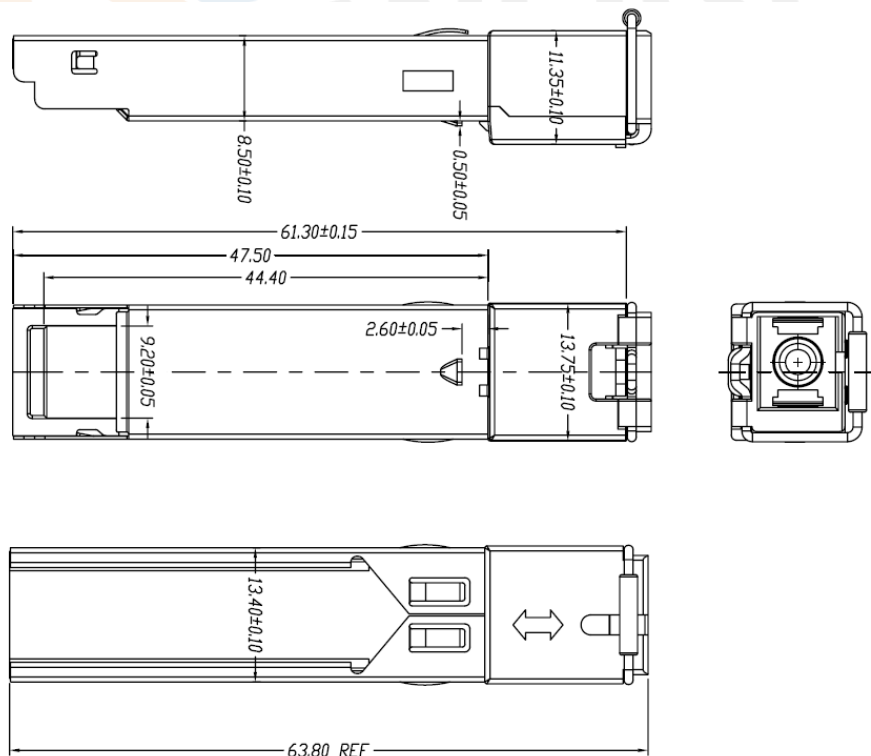

Figure 6 Package Outline